

MB20J/MB26J

MAST BOOM LIFTS



- Versatile electric mast booms
- Ultra-narrow for use in confined spaces
- Superb working envelope including "up & over" capabilities
- Simple to operate and maintain
- Ideal for retail and warehouse applications

 **snorkel**
www.snorkellifts.com

MAST BOOM LIFTS

MB20J/MB26J

DIMENSIONS	MB20J	MB26J
Max. working height	8.1m	9.8m
Max. platform height	6.1m	7.8m
Max. working outreach	2.6m	3.0m
Platform size	0.73m x 0.78m	0.73m x 0.78m
Overall width (A)	0.81m	1.0m
Stowed length (C)	2.41m	2.8m
Stowed height (B)	1.98m	1.98m
Ground clearance	100mm	100mm

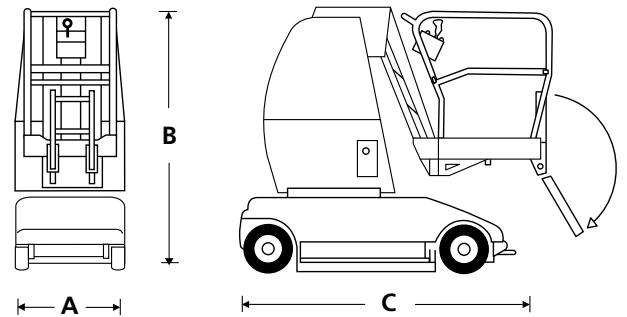

PERFORMANCE		
Platform capacity (SWL)	215kg	215kg
Max. drive height	6.1m	6.1m
Max. wind speed	12.5m/s	12.5m/s
Max. drive speed (stowed)	3.2km/h	3.2km/h
Max. drive speed (elevated)	0.48km/h	0.48km/h
Jib length	1.02m	1.4m
Jib arc	130°	130°
Mast rotation (non-continuous)	360°	360°
Raise/lower time	54/26sec	56/27sec
Gradeability	25%	25%
Inside turning radius	0.3m	0.3m
Outside turning radius	1.83m	2.1m
Tires	13.5 x 4 non-marking rubber	
Controls	proportional controls	
Drive system	electro/hydraulic	

POWER	
Power source	4 x 6V x 375 Ah batteries

WEIGHT		
Weight	3,028kg	3,175kg

WORKING ENVELOPE

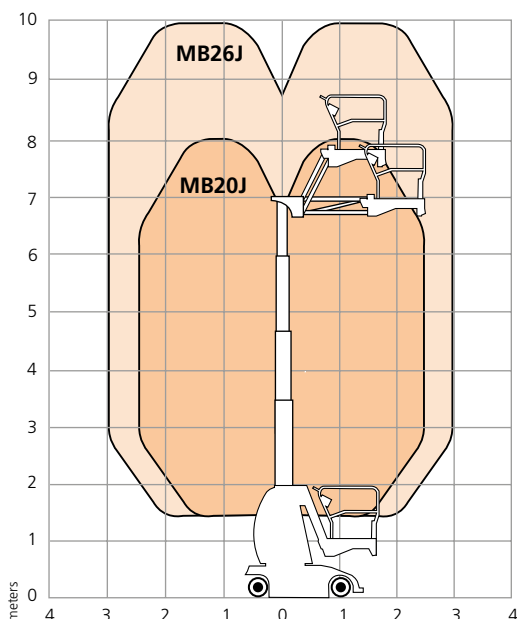

STANDARD FEATURES

- Ultra-tight inside turning radius
- Proportional controls
- Tilt alarm
- Hour meter & on-board diagnostics display
- 2 person + equipment capacity indoor
- 1 person + equipment capacity outdoor
- Power line to platform
- Hydraulic pothole protection system
- Non-marking rubber tires
- Self-seeking automatic battery charger
- Automated battery fill
- 2 year parts & labor, 5 year structural warranty
- ANSI compliant

OPTIONS

- Special paint colors
- Flashing amber light
- Environmental hydraulic oil
- CSA compliant

snorkel www.snorkellifts.com

P.O. Box 1160
 St. Joseph, MO 64502-1160, USA
 Tel: 1 (785) 989-3000
 Toll-free: 1 (800) 255-0317
 Fax: 1 (785) 989-3070
 Email: sales.usa@snorkellifts.com